



FERRARI

REACHSTACKER

T E C H N I C A L D A T A

F500.RS3-V

DATASHEET

CHARACTERISTICS	1.0	Make			CVS FERRARI	
	1.1	Truck type			Reach Stacker	
	1.2	Truck model			F500.RS3-V	
	1.3	Attachment type			Container spreader	
	1.10	1 st row load capacity "on tyres" (C1=1780 mm)	Q	kg	45000	
	1.12	2 nd row load capacity "on tyres" (C2=3850 mm)	Q	kg	32000	
	1.13	3 rd row load capacity "on tyres" (C3=6400 mm)	Q	kg	16500	
	1.20	Load distance of front tires	X	mm	830	
1.22	Wheelbase	Y	mm	6500		
WEIGHTS	2.1	Service weight - Unladen		kg	72400	
	2.2	Axle load at load center C1, with rated load - Front and Rear		kg	100100-17300	
	2.3	Axle load at load center C1, without load - Front and Rear		kg	36100-36300	
DRIVE TRAIN	3.0	Engine Make and Model			CUMMINS X12	
	3.1	Engine Emission Standard of Compliance			EU Stage IIIA - EPA TIER 3	EU Stage V - EPA TIER 4F
	3.2	Rated Power	kW		250 (at 2100 rpm)	250 (at 2100 rpm)
	3.3	Maximum Power	kW		276 (at 1800 rpm)	276 (at 1800 rpm)
	3.4	Rated Torque	Nm		1674 (at 1400 rpm)	1693 (at 1400 rpm)
	3.5	Rated Speed	rpm		2100	2100
	3.6	Number of Cylinders			6	6
	3.7	Displacement		cu. cm	11.800	11.800
	3.8	Transmission manufacturer / type			Dana TE30	
	3.10	Gear - Forward / Reverse			5 / 3	
	3.11	Driving axle			Kessler D102	
	3.20	Service brake			Cooled wet disk brake	
	3.30	Parking brake			Dry disk brake	
	3.31	Steering			Fully hydrostatic	
TIRES	4.0	Tires			Pneumatic	
	4.1	Tires size - Front			18.00 25 40PR	
	4.2	Tires size - Rear			18.00 25 40PR	
	4.3	Wheels - Number Front / Rear (X = driven wheels)			4X / 2	
	4.10	Reference radius - Loaded - Front axle distance from the ground	r	mm	770	
	4.20	Track - Front	T1	mm	3035	
	4.21	Overall width over front tyres	W1	mm	4185	
	4.22	Track - Rear	T2	mm	2890	
4.23	Overall width over rear tyres	W2	mm	3445		
PERFORMANCE	5.0	Travel speed - Laden / Unladen		km/h	21 / 22	
	5.1	Tractive Effort		kN	337	337
	5.3	Gradeability - without Load - at 2 km/h		%	34,2	34,2
	5.4	Gradeability - Rated Load - at 2 km/h		%	18,3	18,3
	5.10	Lifting speed - Lifting and Extension - Laden (70% of rated load) / Unladen		m/s	0.30 / 0.40	
	5.11	Lowering speed - Lowering and Retraction - Laden (70% of rated load) / Unladen		m/s	0.35 / 0.55	
TRUCK DIMENSIONS	6.0	Boom angle - Maximum		deg	60	
	6.1	Spreader distance from the ground - Minimum	H2	mm	1610	
	6.2	Boom height - Fully lowered	H3	mm	4930	
	6.3	Maximum lift height under spreader	H4	mm	15200	
	6.4	Boom height - Maximum	H5	mm	18200	
	6.5	Truck height - Without boom	H6	mm	3880	
	6.6	Seat height - S.I.P.	H7	mm	2800	
	6.7	Ground clearance - Center of wheelbase	M1	mm	310	
	6.8	Overall length	L1	mm	11840	
	6.9	Length without boom	L2	mm	8460	
	6.10	90° Stacking Aisle 20' container spreader central above front axle with 200 mm operating clearance	A1 - 20'	mm	10110	
	6.11	90° Stacking Aisle 40' container spreader central above front axle with 200 mm operating clearance	A1 - 40'	mm	12730	
	6.12	90° Stacking Aisle 20' container with 200 mm operating clearance	A2 - 20'	mm	12705	
	6.13	90° Stacking Aisle 40' container with 200 mm operating clearance	A2 - 40'	mm	13955	
	6.14	Turning radius - Outer	R1	mm	8620	
6.15	Turning radius - Inner	R2	mm	1390		

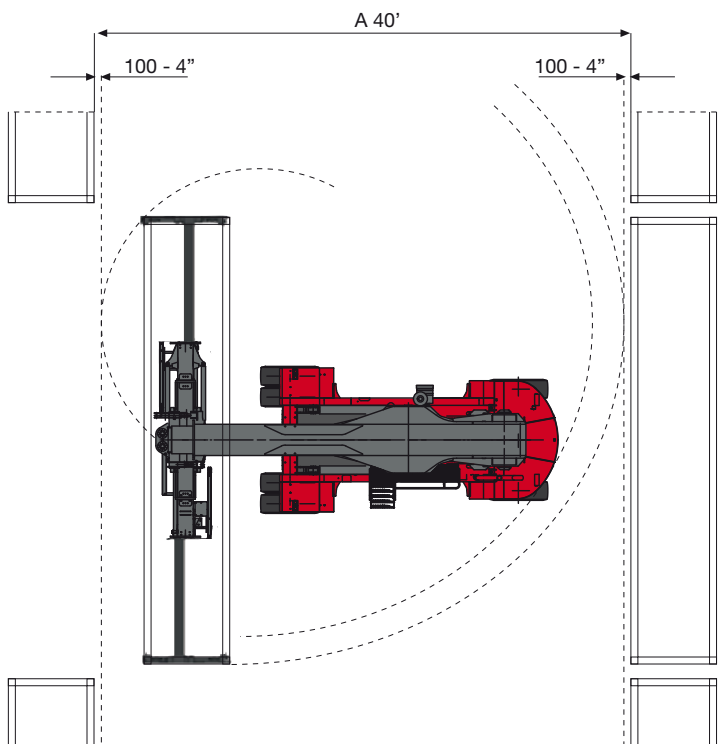
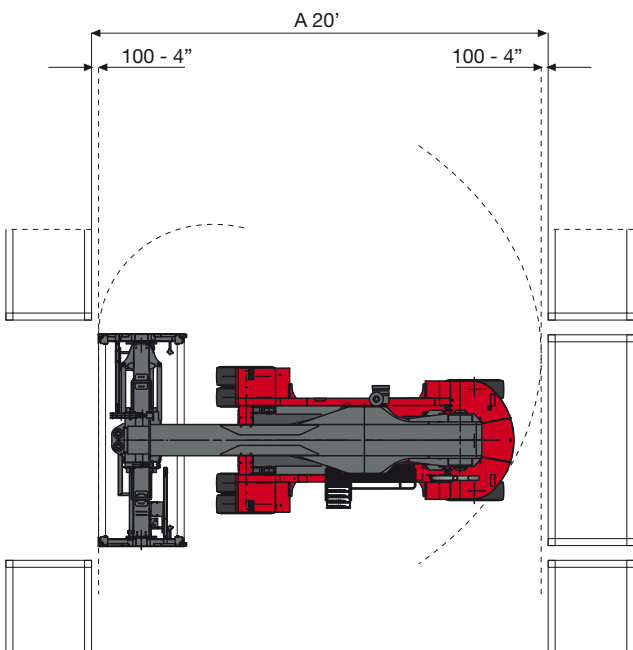
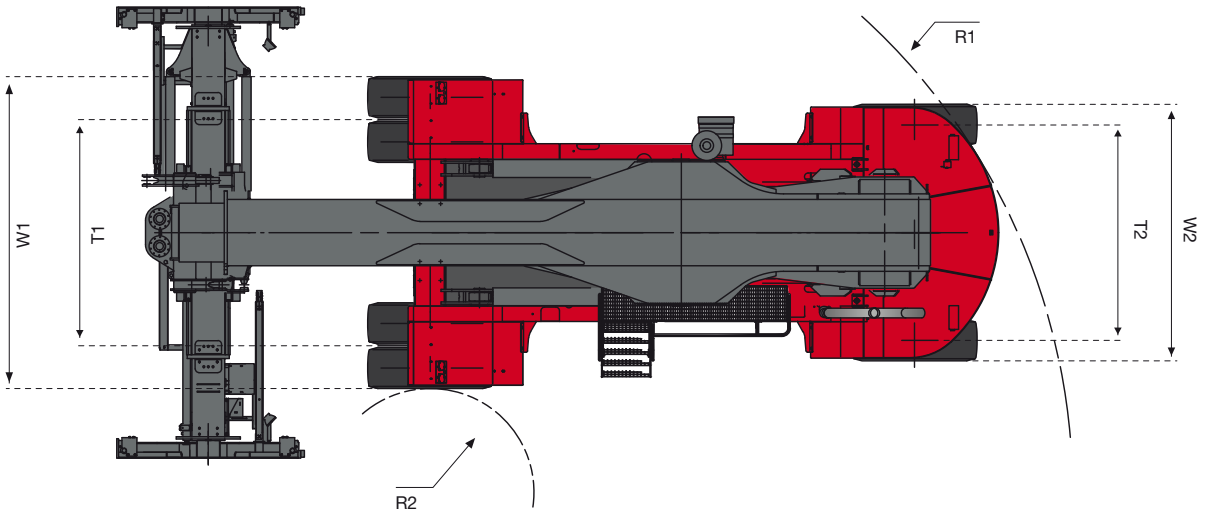
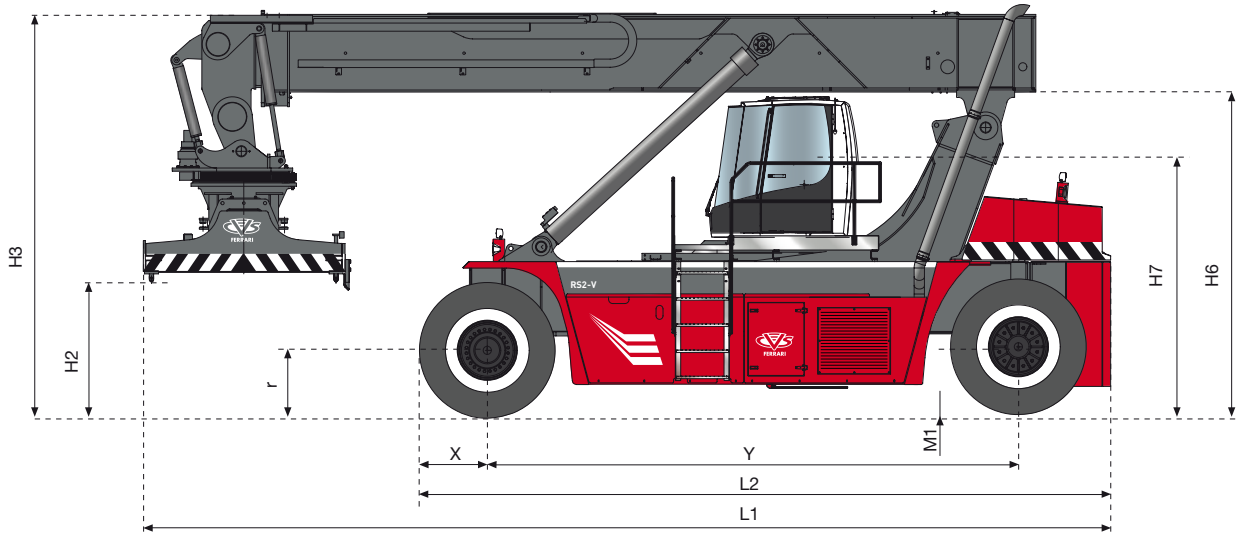

CAPACITY CHARTS

8'6" CTS

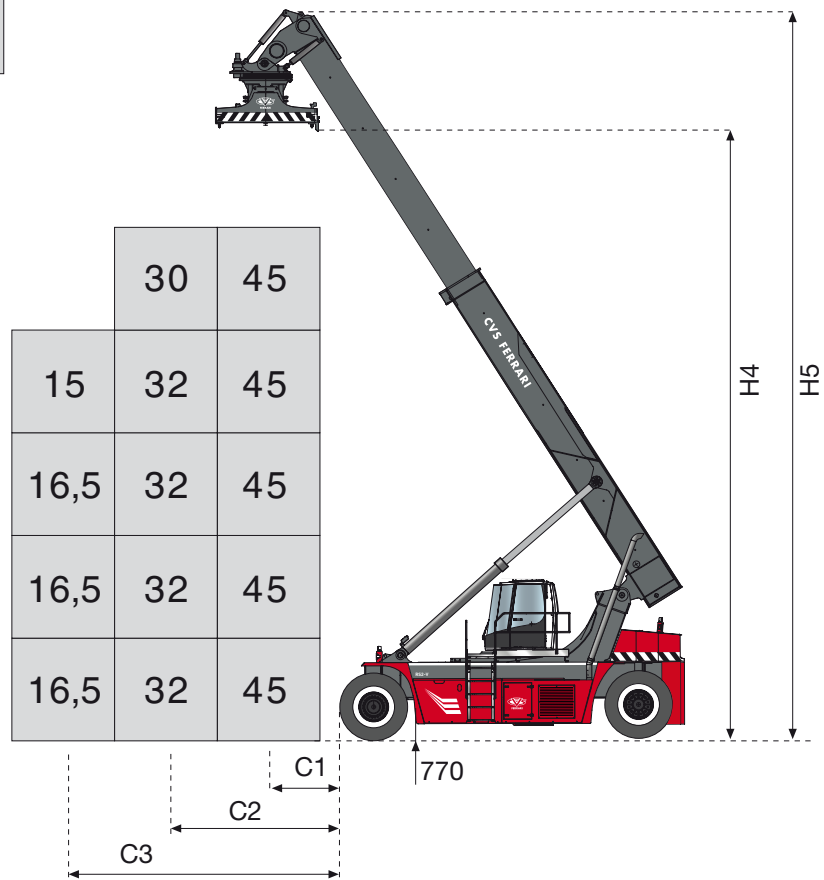

9'6" CTS

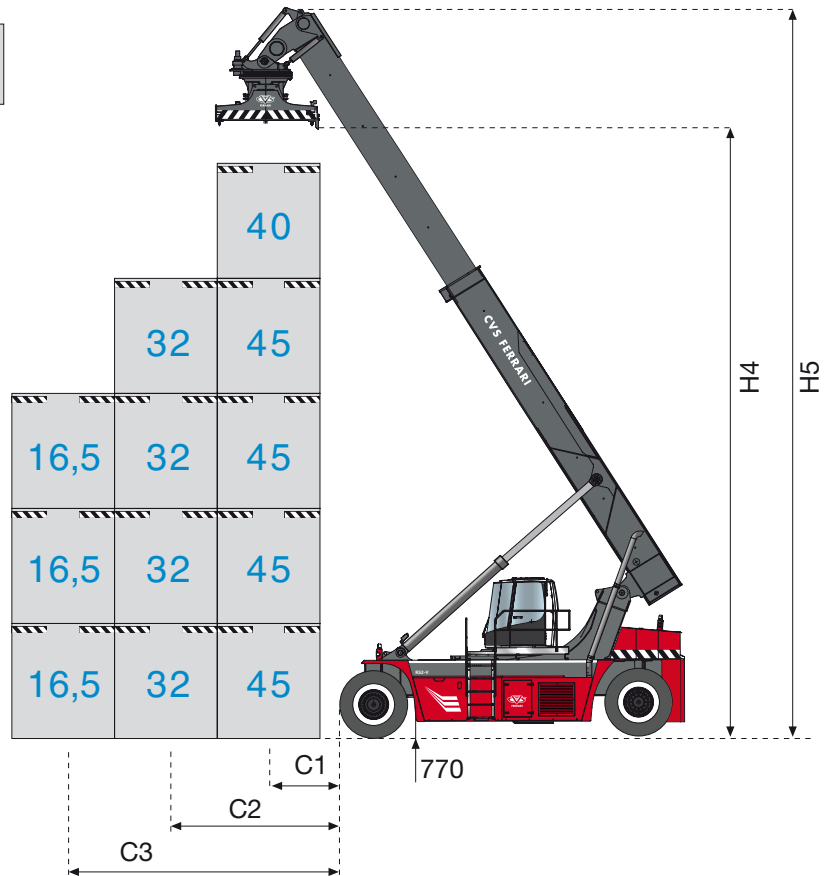

ATTACHMENT

- ISO 20' - 30' - 40' telescopic spreader
- Double beam structure made of high tensile strenght steel St690
- 20' - 30' - 40' automatic positioning
- Hydraulic rotation, proportional speed controlled
- Hydraulic side-shift, proportional speed controlled

- Mechanical pile slope
- N. 4 full floating twist-locks
- N. 4 lifting eyes (10 ton capacity each)
- N. 2 hydraulic rotation motors with gear reducers and brake
- All cylinders mounted externally for easier maintenance

ATTACHMENT TECHNICAL DATA

Make	CVS Ferrari	
Rated Load	kg	45000
Side Shift	mm	± 800
Rotation	deg	- 95° / + 185°
Side tilting - Mechanical	deg	± 3°
Twist-Lock interlock safeties	mechanical and electrical	

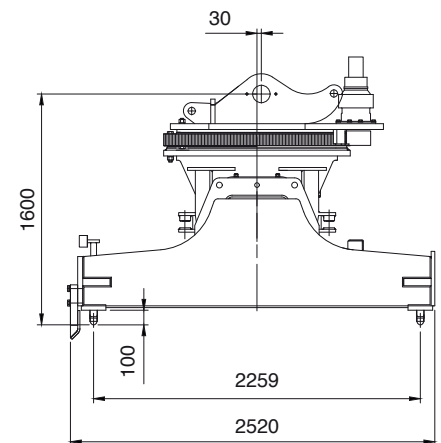
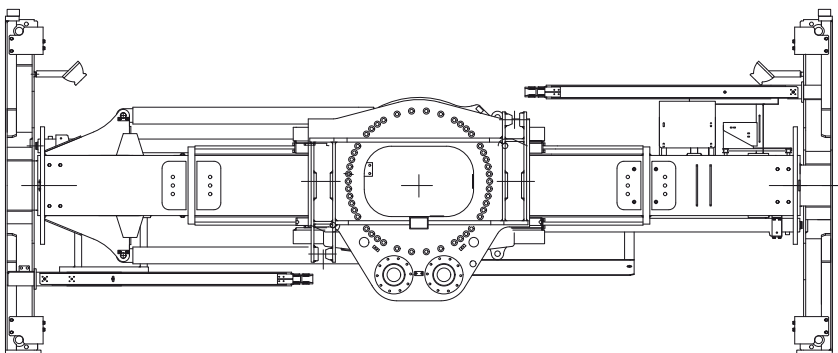
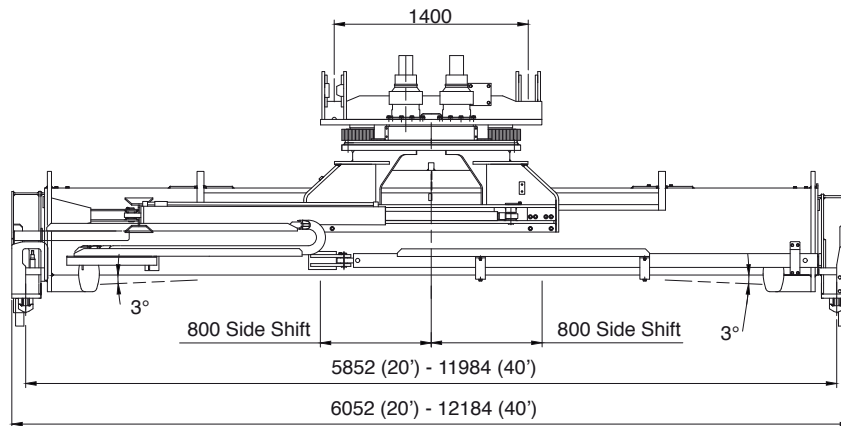



FERRARI

R E A C H S T A C K E R

F500.RS3-V

500RS3-V.T.TSM.0000000.DEC21.EN

CVS FERRARI S.P.A. reserves the right to change details and sizes of the published models without prior notice



FERRARI

CVS FERRARI S.P.A.
VIA EMILIA LOC FAVORITA
29010 ROVELETO DI CADEO (PC) ITALY
Tel. +39.0523.503511
www.cvsferrari.com