



ASPHALT CONTAINER

ASPHALT CONTAINER

- AF50
- AF50/2K
- AF75
- AF75/2K
- AF100
- AF100H
- AF100/2K
- AF100/2KH



Asphalt Container for road maintenance

The OLETTO asphalt container is the perfect solution in modern road maintenance. The hotbox keeps the asphalt hot all day, and is the ideal pothole patcher for repairing asphalt surfaces after laying pipelines, or any other job where you have to patch with small amounts of asphalt.

The advantages of the hotbox are many such as warm asphalt all day, reduced wage costs, by processing easier and much faster, fully automatic temperature control and a hydraulic auger for easy unloading.

The OLETTO thermo asphalt container consists of two separate heating chambers. The chambers are insulated with Rockwool which prevent the asphalt from cooling, and is equipped with new technology including a gas saving system in both chambers.

A HARDOX auger with geared drive leads the asphalt out through a chute to the desired place for repair. The auger is hydraulic driven either by using the hydraulic of the truck or an integrated hydraulic station driven by a gas- or diesel engine.

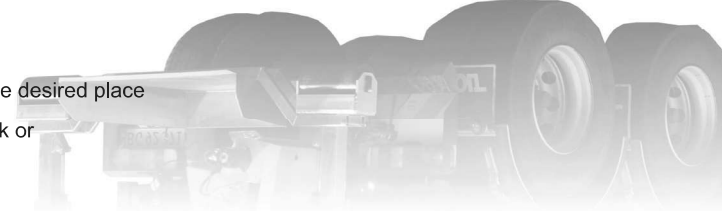

TECHNICAL SPECIFICATIONS

	AF50	AF75	AF100	AF100H
Chambers	1	1	1	1
Thermometer	Digital	Digital	Digital	Digital
Temperature regulation	Automatic	Automatic	Automatic	Automatic
Burner type	Lamella	Lamella	Lamella	Lamella
Max. volume	2,8 m ³	4,2 m ³	5,5 m ³	7,5 m ³
Max capacity	6,2 t	9,3 t	12,2 t	16,7 t
Truck pay load	7,7 t	11,1 t	14,3 t	18,9 t
Weight	1500 kg	1800 kg	2100 kg	2200 kg
Gas consumption	1 kg/h	1,5 kg/h	2 kg/h	2,5 kg/h
Standard colour	RAL1007	RAL1007	RAL1007	RAL1007
Insulation	50 mm	50 mm	50 mm	50 mm
Gas pressure	0,75 bar	0,75 bar	0,75 bar	0,75 bar

ADDITIONAL EQUIPMENT AF50-100



Select the hotbox based on your requirements

A lot of additional equipment are available for the AF50-100 hotbox. Therefore it is easy to select a hotbox with your desired requirements.

- Bituslip sprayer
- Hydraulic lift for vibrator
- External gas burner
- Fire extinguisher in a box
- Bonding Agent tank 100/200L
- Dicky box
- Hydraulic opening of doors
- Extended chute for high truck
- Advanced gas control
- Permanent on a truck
- Permanent on a trailer
- Heating around the auger outlet
- Mechanical legs
- Multi lift system



Automatic temperature control



Mechanical legs



Platform for vibrator



Bonding Agent tank 100/200L



Multilift system



10L Bituslip sprayer

	AF50/2K	AF75/2K	AF100/2K	AF100/2KH
Chambers	2	2	2	2
Thermometer	Digital	Digital	Digital	Digital
Temperature regulation	Automatic	Automatic	Automatic	Automatic
Burner type	Lamella	Lamella	Lamella	Lamella
Max. volume	3,4 m ³	5,1 m ³	6,9 m ³	8,8 m ³
Max capacity	7,5 t	11,4 t	15,5 t	19,6 t
Truck pay load	9,2 t	13,4 t	17,9 t	22,0 t
Weight	1700 kg	2000 kg	2350 kg	2500 kg
Gas consumption	1 kg/h	1,5 kg/h	2 kg/h	2,5 kg/h
Standard colour	RAL1007	RAL1007	RAL1007	RAL1007
Insulation	50 mm	50 mm	50 mm	50 mm
Gas pressure	0,75 bar	0,75 bar	0,75 bar	0,75 bar

TECHNICAL SPECIFICATIONS

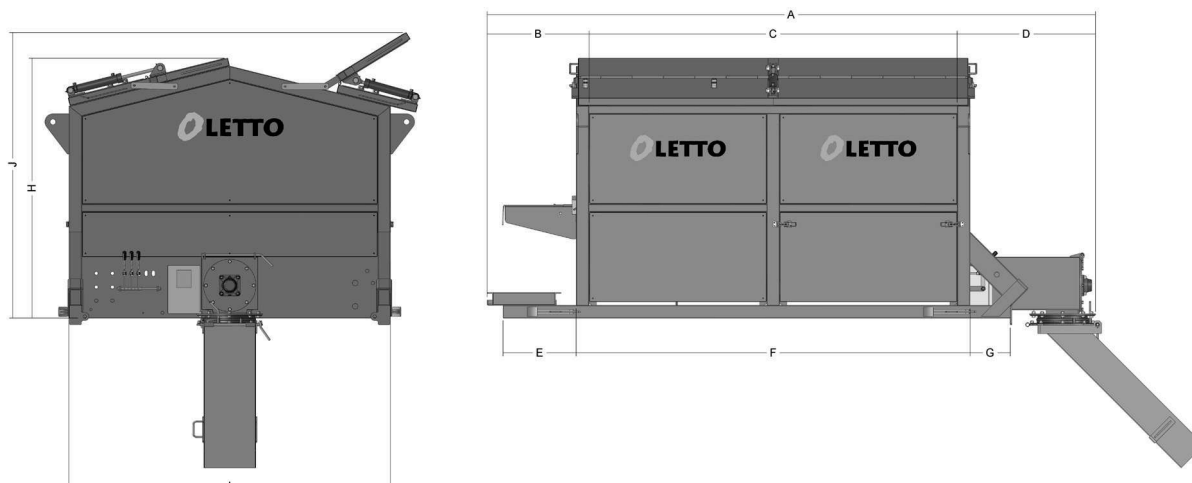

All dimensions are in mm. Dimensions and specifications can be modified without notice.

Model	AF50	AF75	AF100	AF100H
A	3820	4820	5820	5820
B	680	680	680	680
C	2290	3290	4290	4290
D	850	850	850	850
E	455	455	455	455
F	2450	3450	4450	4450
G	250	250	250	250
H	1620	1620	1620	1950
I	2000	2000	2000	2000
J	1930	1930	1930	2260

Model	AF50/2K	AF75/2K	AF100/2K	AF100/2KH
A	3820	4820	5820	5820
B	680	680	680	680
C	2290	3290	4290	4290
D	850	850	850	850
E	455	455	455	455
F	2450	3450	4450	4450
G	250	250	250	250
H	1700	1700	1700	1950
I	2000	2000	2000	2000
J	2010	2010	2010	2260

TECHNICAL SPECIFICATIONS